



TRAVEL'R ARM EXTENSION

These instructions replace the following sections in the standard Travel'r Installation Manual:

Page 5 "Assembling the Awning"
Pages 6-7 "Mounting the Awning"

These instructions are for mounting the Travel'r Patio Awning on RV's with corrugated siding and minimal structure. The extension allows the arm to be securely mounted to the floor line structure.

ASSEMBLING THE AWNING

1. Size the rail extension for the installation:

1a. Measure the distance from the centerline of the awning rail to the center of the floor structure. This will be value "K".

1b. To determine the cut length ("L") of the extension:

L (flat pitch) = $K - 64 \frac{5}{8}$ "

L (steep Pitch) = $K - 57$ "

K = _____

Amount to Subtract - _____

L (Cut Length) = _____

1c. Cut the extension to the length "L". Cut off the end without the hole in the side.

1e. On the back of the extension, measure 4" down from the top and mark. Slide the top of the extension into the rear channel up to the mark and firmly hold or clamp in position.

1f. (Detail B) From the back of the arm, drill two 7/32" holes through the rear channel and into the extension. Attach the extension using two 3/16" pop rivets.

1g. Repeat for the other arm.

2. If the motor cable is to be routed through the RV wall at the top of the arm:

2a. Remove the plastic wrap at the top of the motorized arm. Partially open the arm being careful to not let the arm extend more than 6".

CAUTION

THE ARM IS UNDER TENSION FROM THE GAS SHOCK LOCATED IN THE ARM.

2b. Pull the motor cable from the back of channel and out the hole in the top of the channel.

2c. Close the arm and secure closed position using a plastic wrap or equivalent.

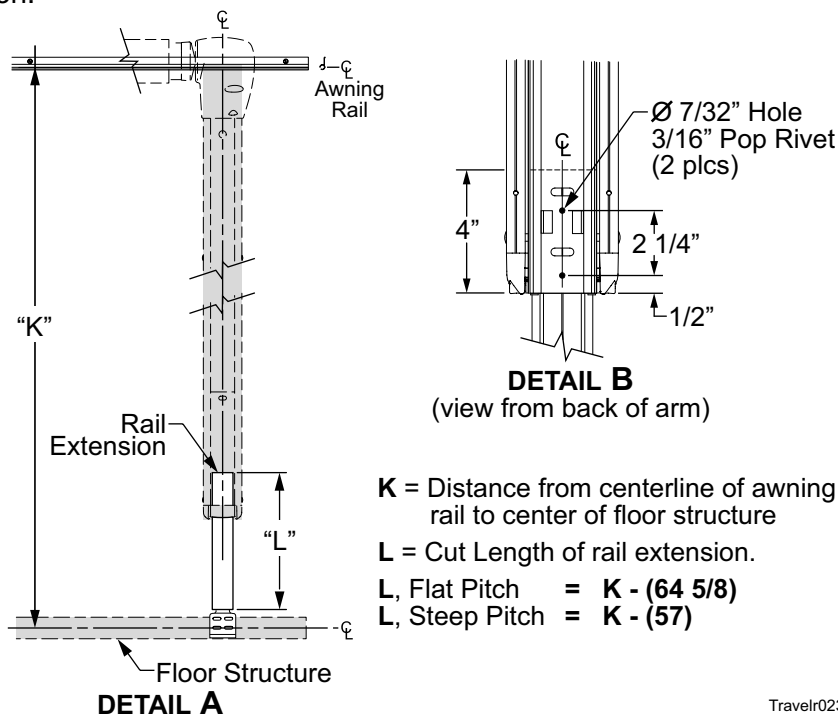

K = Distance from centerline of awning rail to center of floor structure
L = Cut Length of rail extension.
L, Flat Pitch = $K - (64 \frac{5}{8})$
L, Steep Pitch = $K - (57)$

Travelr023

Figure 1. Assembling the Awning.

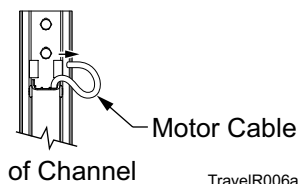

TravelR006a

Figure 2. Top Cable Routing.

3. If the motor cable is to be routed through the RV wall below the floor line:
 - 3a. On the back of the arm, carefully pull the cable out of the channel up to the squared access holes.
 - 3b. Drill a 1/2" hole through the squared hole and into the extension.
 - 3c. Route the cable into the hole and down inside the extension.

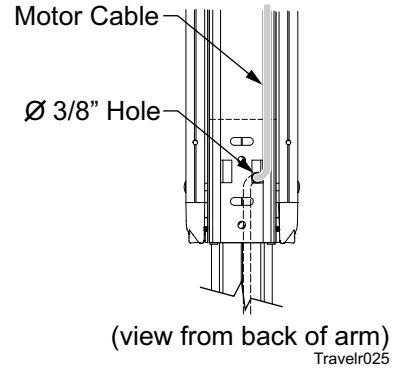

Figure 3. Routing the Cable.

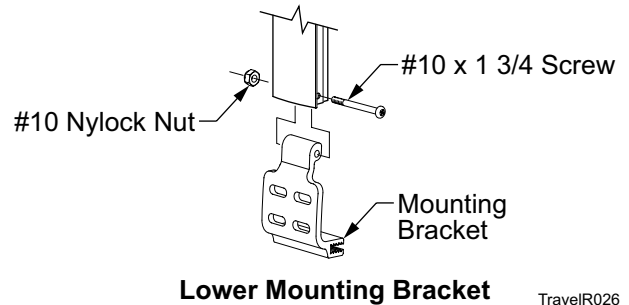
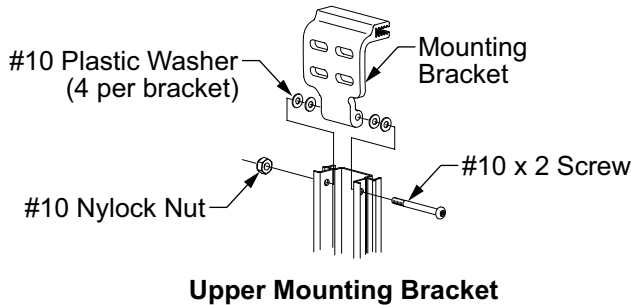

Figure 4. Mounting Brackets.

4. (refer to Figure 4) On each arm attach the top mounting bracket to the channel using the screw, nut and washers as shown.
5. Attach the lower mounting bracket to the extension as shown.
6. Align the roller assembly with the end cap on the motorized arm assembly. Rotate the end cap until the slot in the cap aligns with the empty slot in the roller assembly, and then press the roller assembly fully into the cap. The end cap must seat squarely over the end of the roller assembly when complete.

NOTE: The roller assembly must be oriented with the fabric going over the roller toward the mounting surface.

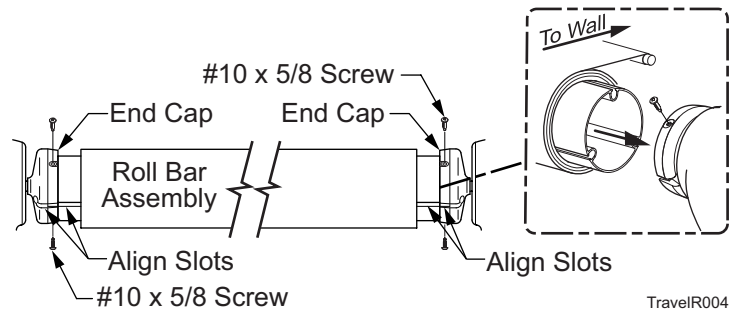

Figure 5. Assembling the Awning.

7. Secure the end cap to the roller assembly using two #10 square-drive screws.
8. Repeat steps 4 through 6 to attach the non-motorized arm assembly to the roller assembly.

⚠ CAUTION

DURING ASSEMBLY AND INSTALLATION, THE ARM ASSEMBLIES MUST REMAIN PERPENDICULAR TO THE ROLLER ASSEMBLY. FAILURE TO HANDLE THE ARM ASSEMBLIES CAREFULLY CAN BEND THE DRIVE SHAFT.

MOUNTING THE AWNING

CAUTION

IT IS RECOMMENDED THAT AT LEAST THREE PEOPLE INSTALL THE AWNING DUE TO ITS SIZE AND WEIGHT.

1. Check the location the awning is to be mounted. Ensure that the awning will not interfere with other equipment on the vehicle, such as a slide out room, light fixtures, exhaust vents etc.
2. Using a non-permanent method of marking, mark the centerline of the RH (motorized) arm. Ensure that it is perpendicular to the awning rail.
3. Unroll the canopy two wraps.

NOTE: While the awning fabric is fairly robust, care must be taken not to snag it on the awning rail.

4. With one person holding each arm, the third person should thread the polyrod (the plastic rod on the edge of the fabric) into the awning rail, starting at one end. Carefully move across the vehicle, gently pulling the fabric into the rail, until the awning is in the pre-determined location.
5. Position the motorized arm on the coach:
 - Align the center of the motorized arm with the centerline marked previously. Butt the top of the rear channel against the awning rail as shown in Figure 6.
 - The arm assembly must be perpendicular to the awning rail.

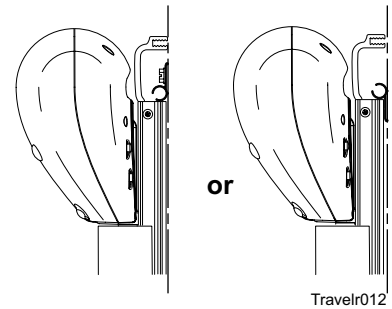

Figure 6. Aftermarket Arm Positioning.

6. Using the lower mounting bracket as a template, drill 5/32" pilot holes into the RV wall and attach the motorized arm using 1/4 x 2 1/2" lag screws. After attaching the lower bracket, it will be necessary to hold the arm in position while attaching the LH (idler) arm.
7. Position the roller assembly so that it is perpendicular to the motorized arm assembly. Position the non-motorized arm perpendicular to the roller assembly.
8. Using the lower mounting bracket as a template, drill 5/32" pilot holes into the RV wall and attach the LH (idler) arm using 1/4 x 2 1/2" lag screws. Hold the arm in position after attaching the lower bracket.
9. Hold the awning closed and carefully remove the plastic wraps at the top of the arms. The awning will partially open.
10. Hold the rear mounting channel against the wall. Ensure that the channel is perpendicular to the awning rail.
11. Drill 5/32" pilot holes and attach the upper mounting brackets to the wall using 1/4 x 2 1/4 lag screws.

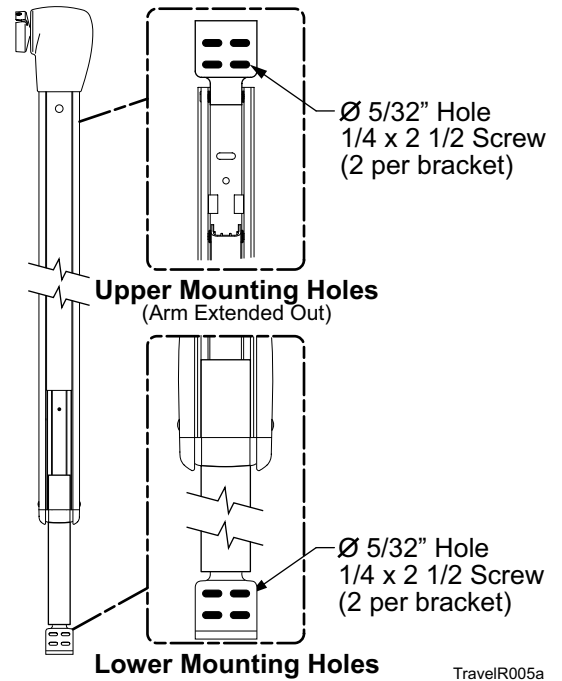

Figure 7. Arm Mounting Holes.